

Model	Voltage	Current	Motor power		Outlet		Rated capacity	Rated head	Max capacity	Max Head	Impeller Passage	Cable
	V	A	kW	HP	in	mm	m³/h	m	m³/h	m	mm	mm²
100C42.2T	380	5.5	2.2	3	4	100	40	8	95	13	50	4G1.5
100C43.7T	380	8.2	3.7	5	4	100	60	11	125	16	55	4G1.5
100C45.5T	380	11.7	5.5	7.5	4	100	65	13	135	20	55	4G2.5
100C47.5T	380	15.7	7.5	10	4	100	80	15	150	24	55	4G4.0

Hard Pipe Installation(Y)

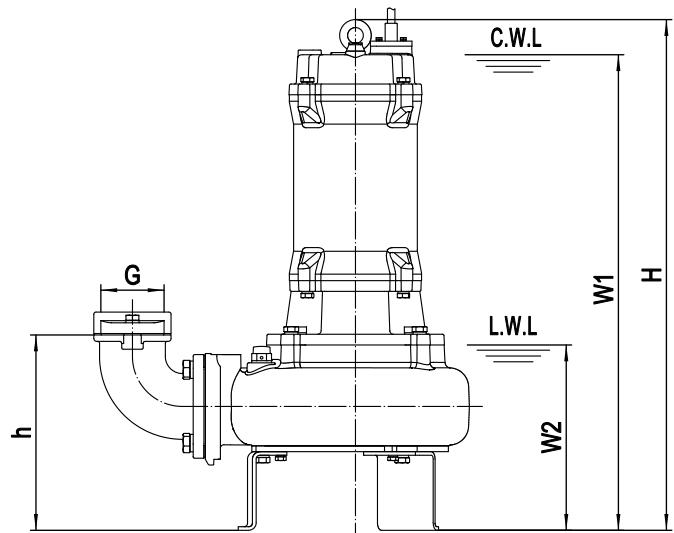
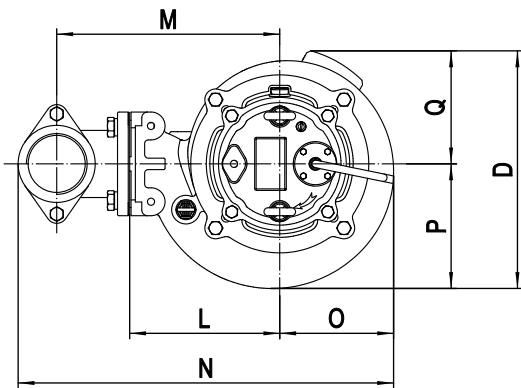

C.W.L : Continuous running water level
L.W.L : Lowest running water level

Dimensions table

Model	G	h	W1	W2	H	O	P	Q	L	D	M	N	N.W	G.W	Packing dimension mm
													kg	kg	
100C42.2T	G4"	323	570	225	650	159	174	158	210	332	342	606	81	89	680×350×400
100C43.7T	G4"	323	645	235	715	159	174	158	210	332	342	606	93	102	740×350×400
100C45.5T	G4"	333	775	335	800	191	202	192	260	394	412	708	138	150	930×430×490
100C47.5T	G4"	333	800	335	845	191	202	192	260	394	412	708	151	164	970×430×490