

0.75~1.5kW 2P
 TYPE T
 50Hz : 2850rpm

Specification

- Insulation class : B
- Protection class : IP68
- Water temperature : up to 40°C
- PH : 6 to 10
- Density of liquid : 1.3g/cm³
- Power supply : three phase 380V ±10%, 50Hz
- Motor protection : built in
- Capacity : up to 52m³/h
- Head : up to 13m
- Maximum immersion depth : 10m
- Cable Length : 8m



Hard Pipe Installation(Y)

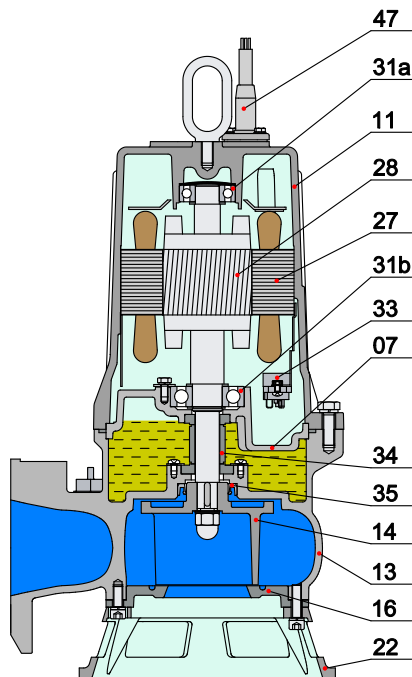
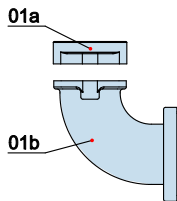

Materials of construction

Item No.	Part name	Material
01a	Hose coupling	Cast iron
01b	Hose coupling	Cast iron
07	Bearing house	Cast iron
11	Motor body	Cast iron
13	Pump body	Cast iron
14	Impeller	Cast iron
16	Inlet plate	Ductile iron
17	Coupling adapter	Cast iron
22	Seat assembly	Cast iron
22a	Coupling seat	Cast iron
22b	Upper guide support	Cast iron
27	Stator	
28	Rotor	Shaft : AISI304SS
30	Flange	Cast iron
31a	Bearing	Ball bearing
31b	Bearing	Ball bearing
33	Motor protector	
34	Mechanical seal	Sic-Sic/Carbon-Sic
35	Oil seal	
47	Cable	