

DIMENSIONS AND WEIGHT

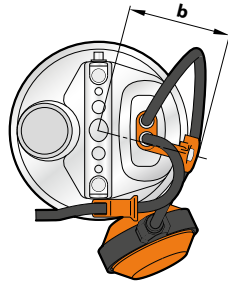

Standard installation

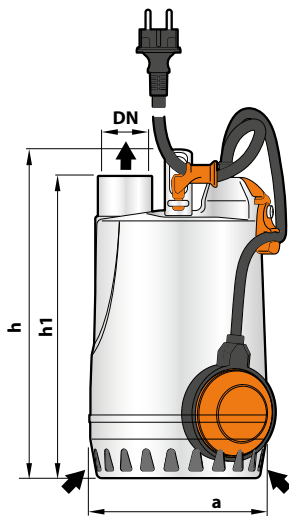
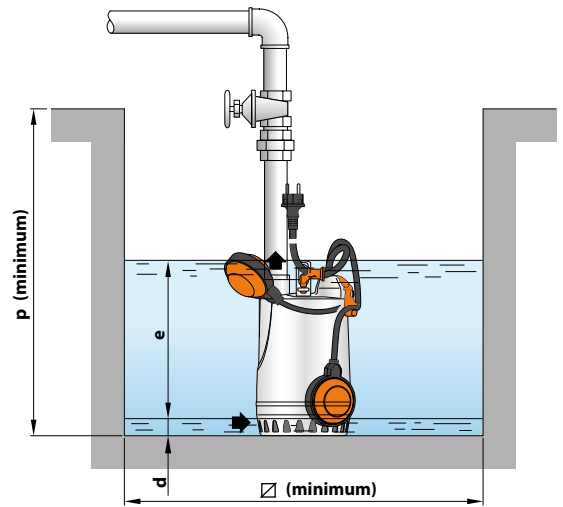

MODEL	PORT DN	DIMENSIONS mm								kg		PALLETIZATION					
		a	b	h	h1	d	e	p	Ø	1~	3~	GROUPAGE n. pumps	CONTAINER n. pumps				
RXm 1	1 1/4"	147	24	269	246	14	variable	350	350	6.1	5.5	96	144				
RXm 2				298	277									7.6	7.0	96	144
RXm 3																	

Version with vertical float switch

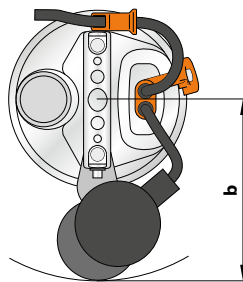
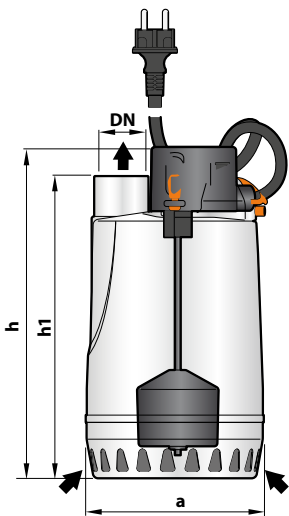

Standard installation

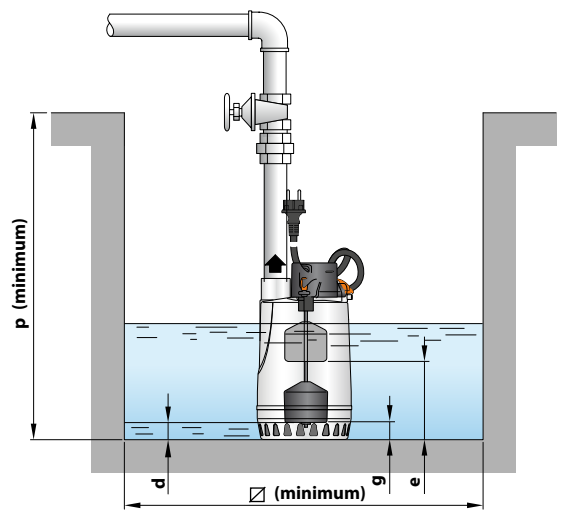

MODEL	PORT DN	DIMENSIONS mm								kg		PALLETIZATION				
		a	b	h	h1	d	e	g	p	Ø	1~	GROUPAGE n. pumps	CONTAINER n. pumps			
RXm 1-GM	1 1/4"	147	150	270	247	14	145	40	350	240	6.2	80	120			
RXm 2-GM				300	277		175	45						7.5	80	120
RXm 3-GM																

ABSORPTION

MODEL	VOLTAGE		
	230 V	240 V	110 V
RXm 1	1.5 A	1.4 A	3.0 A
RXm 2	2.0 A	2.0 A	4.0 A
RXm 3	3.6 A	3.4 A	7.2 A